

i100 SR3 INDUSTRIAL DOOR

LPCB CERTIFIED STEEL SECURITY SHUTTER :: LPS1175 SR3

High security steel security shutter offering large aperture coverage, improved insulation properties, and insurance-approved accreditation. The i100 SR3 has been tested by the Loss Prevention Certification Board to the LPS1175 (7.0) SR3 rating, for at-risk security industrial, commercial and public applications. Maximum size of 100m² with an outboard motor, with tubular motor options available for smaller openings.

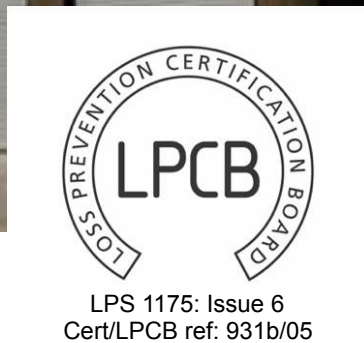

APPLICATIONS

High security public, commercial & industrial sites. The i100 Elite has been tested by the Loss Prevention Certification Board LPS1175 (7.0), rated SR3, and awarded 'Secured by Design' status. Suitable for internal face fix installation only.

LOCKING MECHANISMS

The i100 incorporates a bullet locking system situated approx. 1m from ground level, fixed to each guide channel; central ground anchor on the bottom lath on shutters over 3 metres wide.

CURTAIN SLAT

Double skin mild steel slat with 81mm face. Wall thickness 1.2mm, with optional polystyrene insulation.

Finish: Galvanised finish as standard. Option to powder coat any RAL / BS colour or to choose from a range of plastisol finishes (surcharges apply).

Visible Face:	81mm
Weight per m ² :	37kg
Maximum Width:	7000mm
Maximum Area:	10m ² (tubular) 49m ² (outboard)
Slat U-Value:	1.5 W/m ² K (with insulated core)

CASING

Galvanised steel casing & end plates as standard. Optional fascia / custom design casings available on request (surcharge applies).

Finish: Galvanised finish as standard. Option to powder coat any RAL / BS colour (surcharge applies).

Guide Height (mm)	Plate Size (mm)	Motor
1500	400	Tubular / Outboard
2500	450	Tubular / Outboard
3250	500	Tubular / Outboard
4000	550	Outboard
5000	600	Outboard

Plate sizes shown as a guide only and may vary. Note that outboard motors are generally larger than the plate itself.

BOTTOM RAIL

Galvanised steel bottom rail with rubber weather seal.

GUIDE CHANNELS

85mm wind guides as standard.

OPERATION

Electric, Tubular Motor: Tubular motor with internal rocker or external key switch as standard with safety brake as appropriate to comply with legislation. Manual override facility & crank handle as required (surcharge applies).

Electric, Outboard Motor: Three phase motors with safety brake, chain manual override & TS959 push button control station as standard.

Both tubular & outboard motors have numerous control option variants such as group, remote or mobile phone activation.

CE compliant to all applicable directives and regulations.

i100 SR3 INDUSTRIAL DOOR

LPCB CERTIFIED STEEL SECURITY SHUTTER :: LPS1175 SR3

FRONT FACE & FIXING DETAIL

Viewed from secure side (internal)

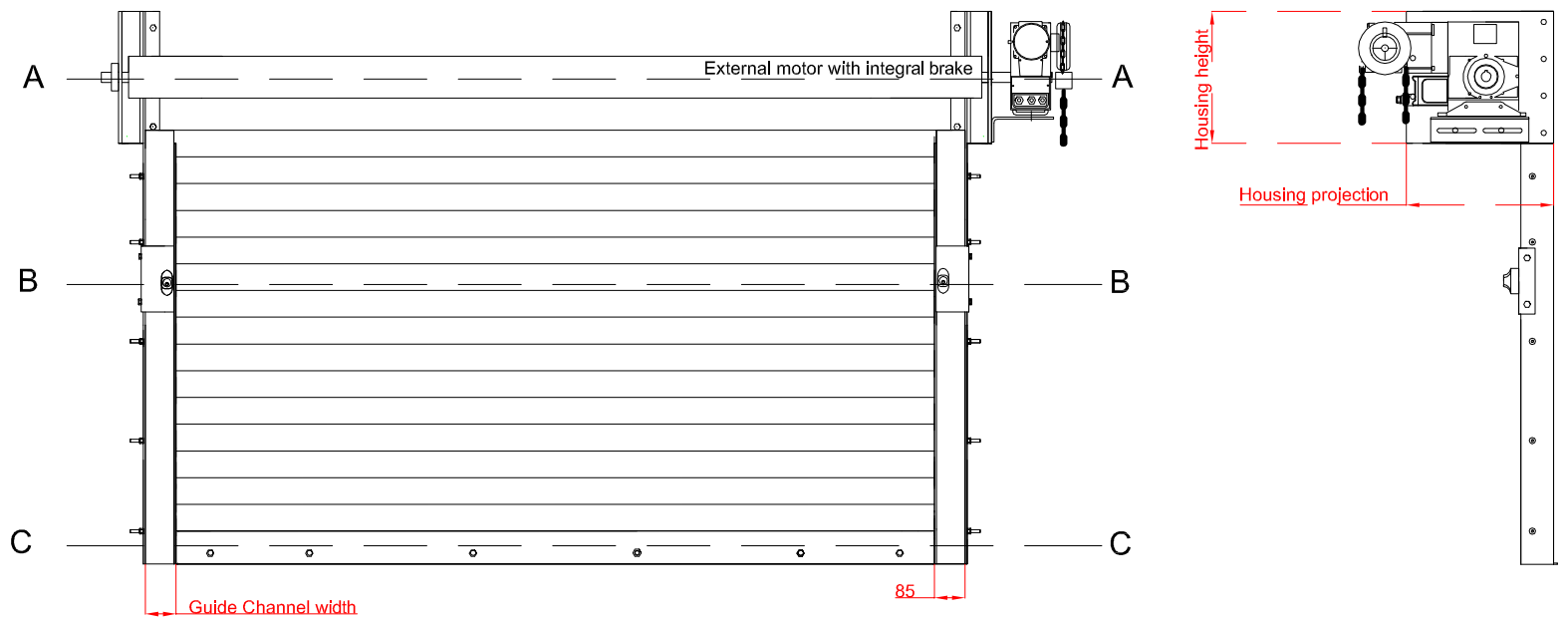

Plan - A

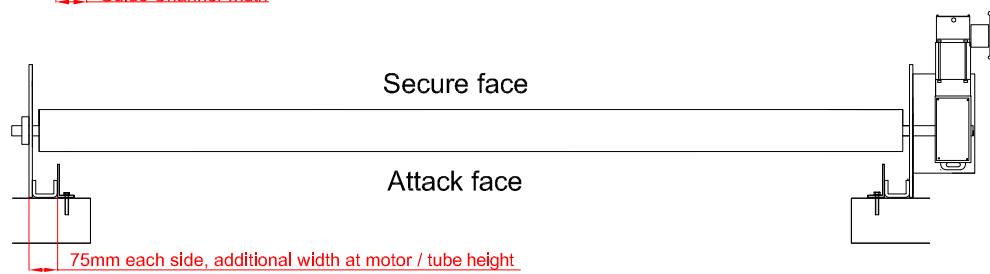

Plan - B



Plan - C

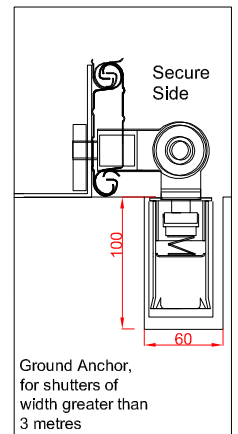
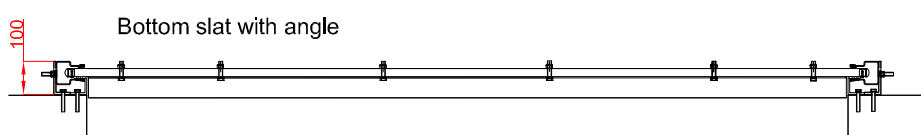

SLAT PROFILE

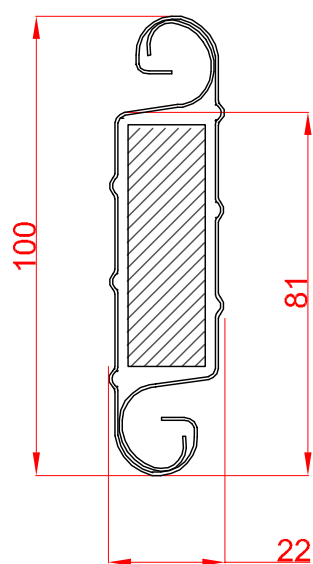

GUIDE CHANNEL & ANGLE

