

# ELEKTROMATEN® SI

Safedrive®

For driving:  
Roller shutters and rolling grilles  
which require an anti-fallback device

Series SG63F  
SI 10.15 - SI 25.15

Series SG85F  
SI 25.10 - SI 65.15

Series SG115F  
SI 75.10 - SI 180.6

“Safedrive®” ELEKTROMATEN SI are special drives for industrial doors which require an anti-fallback device. The patented safety brake is built into the gear. The drive unit is fitted directly to the door shaft. Safedrive® ELEKTROMATEN comprises of:  
Worm gear with safety brake and hollow shaft, emergency manual operator, integrated limit switches and electrical motor.

## Patented built-in safety brake

- Safety against failure of worm or wheel
- Independent of speed / direction
- Maintenance free, self-monitoring
- Excellent damping characteristics in operation

## Approvals and certificates

### ELEKTROMATEN

Type test according to:  
DIN EN 12453  
DIN EN 60335-1  
DIN EN 60335-2-103  
TÜV NORD CERT GmbH



### Built-in safety brake

Certificate of conformity according to:  
DIN EN 12604 / 12605  
ift Rosenheim GmbH

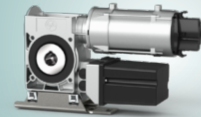

SG63F



SG85F

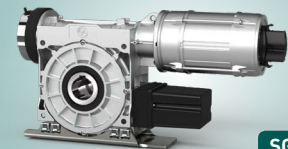

SG115F



1



2



3



4

## Emergency manual operation

- Hand crank NHK 1
- Hand chain operator KNH 2

## Limit switches

- Mechanical limit NES 3
  - 2 operating, 2 emergency- and 2 auxiliary limit switches
- Digital limit DES 4
  - Absolute encoder, after a power failure, re-adjustment is not required

## Mounting

- Floating foot (standard fitting)
- Torque bracket
- Moving-torque bracket

## Special versions

- Increase of movements per hour
- Higher protection class
- Other voltages and frequencies
- Explosion-proof according to ATEX (page 6.011)
- ELEKTROMATEN SI with built-on frequency inverter (page 1.101)

## Door controls

- Simple connection by means of non-interchangeable plug connections allowing simple exchange with other GfA control panels
- Control voltage: 24 V
- Frequency: 50 Hz / 60 Hz
- Mains supply:  
1N~230 V, 3~230 V, 3N~400 V, 3~400 V

Details of all GfA door controls can be found in Section 8.

# 1. Technical data

ELEKTROMATEN Series		SI 10.15 SG63F	SI 17.15 SG63F	SI63 25.15 SG63F <sup>1</sup>	SI 25.10 SG85F	SI25.15WS SG85F	SI 40.10 SG85F	SI 40.15 SG85F	SI45.7WS SG85F
Output torque	Nm	100	170	250	250	250	400	400	450
Output speed	rpm	15	15	15	10	15	10	15	7
Output shaft / hollow shaft (Ø)	mm	30	30 / 40	30 / 40	30 / 40	30 / 40	40	40	40
Locking torque <sup>2</sup>	Nm	420	420	510	635	635	760	760	1100
Safety brake (approval number)		14-003612-PR02	14-003612-PR02	14-003612-PR02	14-003612-PR03	14-003612-PR03	14-003612-PR03	14-003612-PR03	14-003612-PR03
Max. holding torque <sup>3</sup>	Nm	170	170	250	250	250	400	400	450
Max. output speed OPEN / CLOSE for frequency inverter operation <sup>4</sup>	rpm	26 / 15	26 / 15	26 / 15	18 / 15	--	18 / 15	26 / 15	--
Motor power	kW	0,30	0,40	0,55	0,55	0,75	0,75	0,85	0,75
Supply voltage	V	3-230 / 400	3-230 / 400	3-230 / 400	3-230 / 400	1N-230	3-230 / 400	3-230 / 400	1N-230
Operating frequency	Hz	50	50	50	50	50	50	50	50
Operating current <sup>5</sup>	A	2,6 / 1,5	3,7 / 2,2	4,0 / 2,3	3,1 / 1,8	8,0	5,1 / 3,0	4,4 / 2,6	8,0
Max. movements per hour <sup>6/7</sup>		20	20	20	20	14	16	16	8
Limit switch range <sup>8</sup>		20	20 (40)	20 (40)	20 (60, 110)	20 (60, 110)	20 (60, 110)	20 (60, 110)	20 (60, 110)
Max. hand force NHK / SK and / or KNH <sup>9</sup>	N	65 / 172	80 / 89	118 / 132	85 / 95	85 / 95	136 / 151	136 / 151	78 / 87
Weight	kg	15	16	19	24	27	26	23	33
Spare parts: Catalogue page		9.054	9.054	9.054	9.055	9.055	9.055	9.055	9.055
Part no. installation drawing (dxf, dwg)		50001039	50001039	50001713	50000580	50000751	50000580	50000580	50001571
Part no. ELEKTROMATEN		Ø 30 10003490	Ø 30 10003055 Ø 40 10003830	Ø 30 10003166 Ø 40 10003950	Ø 30 10002363 Ø 40 10004532	Ø 30 10002514 Ø 40 10002559	Ø 40 10002367	Ø 40 10002368	Ø 40 10003600

ELEKTROMATEN Series		SI 55.10 SG85F	SI 55.15 SG85F	SI 65.10 SG85F	SI 65.15 SG85F	SI 75.10 SG115F	SI 75.15 SG115F	SI 100.10 SG115F	SI 140.7 SG115F	SI 180.6 SG115F
Output torque	Nm	550	550	650	650	750	750	1000	1400	1800
Output speed	rpm	10	15	10	15	10	15	10	7	6
Output shaft / hollow shaft (Ø)	mm	40	40	40	40	55	55	55	55	60
Locking torque <sup>2</sup>	Nm	1100	1100	1100	1100	2800	2800	2800	2800	3125
Safety brake (approval number)		14-003612-PR03	14-003612-PR03	14-003612-PR03	14-003612-PR03	14-003305-PR01	14-003305-PR01	14-003305-PR01	14-003305-PR01	14-003305-PR01
Max. holding torque <sup>3</sup>	Nm	550	550	650	650	750	750	1000	1400	1800
Max. output speed OPEN / CLOSE for frequency inverter operation <sup>4</sup>	rpm	18 / 18	26 / 26	15 / 15	15 / 15	18 / 18	26 / 26	18 / 18	12 / 12	10 / 10
Motor power	kW	0,75	1,10	0,75	1,10	1,10	1,10	1,30	1,10	1,30
Supply voltage	V	3-230/400	3-230/400	3-230/400	3-230/400	3-230/400	3-230/400	3-230/400	3-230/400	3-230/400
Operating frequency	Hz	50	50	50	50	50	50	50	50	50
Operating current <sup>5</sup>	A	7,2 / 4,2	7,2 / 4,2	7,2 / 4,2	7,2 / 4,2	7,0 / 4,1	8,1 / 4,7	11,2 / 6,5	7,0 / 4,1	11,2 / 6,5
Max. movements per hour <sup>6/7</sup>		16	16	10	12	14	14	12	10	4
Limit switch range <sup>8</sup>		20(60,110)	20(60,110)	20(60)	20(60)	20(60,110)	20(60,110)	20(60,110)	20(30)	20(30)
Max. hand force NHK / SK and / or KNH <sup>9</sup>	N	320 / 158	320 / 158	233 / 188	233 / 188	290 / 234	290 / 234	349 / 282	263 / 212	348 / 281
Weight	kg	30	30	33	33	44	42	46	51	54
Spare parts: Catalogue page		9.055	9.055	9.055	9.055	9.056	9.056	9.056	9.056	9.056
Part no. installation drawing (dxf, dwg)		50000734	50000734	50000734	50000734	50000794	50000794	50000794	50000795	50001524
Part no. ELEKTROMATEN		10002479	10002480	10005061	10005062	10002402	10002535	10002536	10002537	10003765

Generally applies: Degree of protection IP65 (combined with WS 900: IP54), permissible temperature range -10 °C...+40 °C (+60 °C), operating sound pressure level SPL <70 dB(A)  
<sup>1</sup> Customised designs of the SI 25.15 (e.g. for other voltages) are realised, in part, with the SG85F gearbox series (please contact us, in case of queries) · <sup>2</sup> See 3.5 · <sup>3</sup> Maximum torque that may act on the output shaft of the drive unit when the door is stationary · <sup>4</sup> We recommend the selection of a special GfA ELEKTROMATEN-FI for use with frequency inverter, OPEN drive speed at 87 Hz, see 3.7 · <sup>5</sup> The max. current in door drives can reach up to 4x the rated operating current for limited periods, see 3.6 and 3.7 · <sup>6</sup> When using a temperature range of +40 °C...+60 °C use half of maximum movements per hour, see also 3.2 · <sup>7</sup> The specified value must be halved when considering cycles per hour according to EN 60335-2-103 · <sup>8</sup> Maximum revolutions of hollow shaft · <sup>9</sup> See 3.4

## 2. Selection chart

Roller shutters Tube EN 10220 [mm]	SI 10.15		SI 17.15		SI 163 25.15		SI 25.10		SI 25.15 WS		SI 40.10		SI 40.15		SI 45.7 WS	
	F [N]	v <sub>a</sub> [cm/s]	F [N]	v <sub>a</sub> [cm/s]	F [N]	v <sub>a</sub> [cm/s]	F [N]	v <sub>a</sub> [cm/s]	F [N]	v <sub>a</sub> [cm/s]	F [N]	v <sub>a</sub> [cm/s]	F [N]	v <sub>a</sub> [cm/s]	F [N]	v <sub>a</sub> [cm/s]
101,6 x 3,6	1316	9,6	2237	9,6	3289	9,6	3289	6,4	3289	9,6	--	--	--	--	--	--
108,0 x 3,6	1250	10,1	2125	10,1	3125	10,1	3125	6,7	3125	10,1	5000	6,7	5000	10,1	5625	4,7
133,0 x 4,0	1046	12,0	1778	12,0	2614	12,0	2614	8,0	2614	12,0	4183	8,0	4183	12,0	4706	5,6
159,0 x 4,5	894	14,1	1520	14,1	2235	14,1	2235	9,4	2235	14,1	3575	9,4	3575	14,1	4022	6,6
177,8 x 5,0	--	--	1375	15,5	2022	15,5	2022	10,4	2022	15,5	3236	10,4	3236	15,5	3640	7,2
193,7 x 5,4	--	--	--	--	1872	16,8	1872	11,2	1872	16,8	2995	11,2	2995	16,8	3336	7,8
219,1 x 5,9	--	--	--	--	--	--	--	--	--	--	2677	12,5	2677	18,8	3011	8,8

Roller shutters Tube EN 10220 [mm]	SI 55.10		SI 55.15		SI 65.10		SI 65.15		SI 75.10		SI 75.15		SI 100.10		SI 140.7		SI 180.6	
	F [N]	v <sub>a</sub> [cm/s]	F [N]	v <sub>a</sub> [cm/s]	F [N]	v <sub>a</sub> [cm/s]	F [N]	v <sub>a</sub> [cm/s]	F [N]	v <sub>a</sub> [cm/s]	F [N]	v <sub>a</sub> [cm/s]	F [N]	v <sub>a</sub> [cm/s]	F [N]	v <sub>a</sub> [cm/s]	F [N]	v <sub>a</sub> [cm/s]
159,0 x 4,5	4916	9,4	4916	14,1	5810	14,1	5810	14,1	6704	9,4	6704	14,1	--	--	--	--	--	--
177,8 x 5,0	4449	10,4	4449	15,5	5258	15,5	5258	15,5	6067	10,4	6067	15,5	8089	10,4	11325	7,2	--	--
193,7 x 5,4	4118	11,2	4118	16,8	4867	16,8	4867	16,8	5615	11,2	5615	16,8	7487	11,2	10482	7,8	13477	6,7
219,1 x 5,9	3680	12,5	3680	18,8	4350	18,8	4350	18,8	5019	12,5	5019	18,8	6692	12,5	9368	8,8	12045	7,5
244,5 x 6,3	3327	13,8	3327	20,8	3932	20,8	3932	20,8	4537	13,8	4537	20,8	6049	13,8	8469	9,7	10888	8,3
273,0 x 6,3	--	--	--	--	3549	23,0	3549	23,0s	4096	15,3	4096	23,0	5461	15,3	7645	10,7	9829	9,2
298,5 x 7,1	--	--	--	--	--	--	--	--	3768	16,7	3768	25,0	5024	16,7	7033	11,7	9042	10,0
323,9 x 7,1	--	--	--	--	--	--	--	--	--	--	--	--	4653	18,0	6514	12,6	8375	10,8

■ F = Lift [N]

■ v<sub>a</sub> = Initial speed [cm/s]

■ Includes 20 % friction for single-wall profiles (profile thickness 20 mm)

■ Read note in 3.2

## 3. Notes

### 3.1 European directive

In accordance with the product standard EN 13241 Doors- and EN 12453 Safety in use of power operated doors-Requirements.

### 3.2 Selection chart / Movements per hour

The specified movements per hour (see Technical data) apply to an even distribution and the limit switch range first mentioned and must not be exceeded. For other limit switch ranges or heavily used doors, the drag forces must be reduced (enquire).

The selection chart includes 20 % friction for roller shutters with single-wall profiles (profile thickness 20 mm) and 10 % friction for sectional doors.

Reduce the weight by a further 20 % for vertical lifted doors and insulated shutters with double walled, thick and/or deep sections. Do not calculate using the tube diameter. The highest torque will occur normally after 1-2 turns of the barrel from close.

### 3.3 Gear self-braking / Brake

Drives without an electric brake have a self-sustaining worm gear and stop automatically.

On drives with an electric brake, stopping is achieved by the external brake. Brake inspection must always be carried out by qualified service engineers.

### 3.4 Manual operation

In accordance with EN 12453 and 12604 hand force up to 390 N is permissible. For large, heavy doors, manual operation is only used for closing the door. In the case of drive units with an electric brake; emergency manual operation is carried out against the closed brake (Read note in 3.3).

### 3.5 Locking torque / Holding torque

The permissible loads on walls, fastenings, mountings and transmission elements must not be exceeded, even for maximum holding torques or locking torques.

### 3.6 Motor overload protection

Motor overload protection must be able to withstand 4x the operating motor current because the starting current of the drive unit can reach these levels for short periods.

### 3.7 Use with external frequency inverter

We recommend ELEKTROMATEN FI with an integrated frequency inverter (page 1.101).

For external frequency inverters applies:

A higher than recommended drive speed puts extra load onto the gear. This extra load must be taken into account when sizing a drive by reducing the available output torque.

Increasing the drive speed by 10 % reduces the admissible drive torque by 5 %. In the case of higher drive speeds reduce the drive torque accordingly (enquire if necessary).

The admissible drive speeds may not be exceeded (see Technical data). The operating forces must comply with EN 12453, and the corresponding EMC directives must likewise be observed.

If selecting a frequency inverter, note that the starting current of the drive unit can reach 4x the operating motor current.

## 4. Dimensions

### 4.1 SI 10.15 – SI63 25.15

SG63F

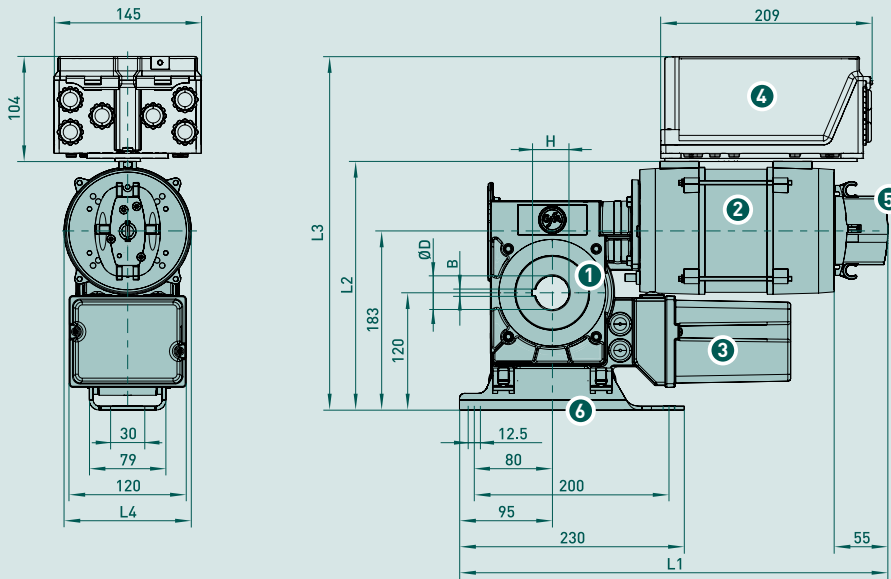

- 1 Worm gear with safety brake
- 2 Motor
- 3 Limit switch

- 4 Optional: WS 900 control panel, removable, with 0,8 m cable
- 5 Hand crank NHK
- 6 Floating foot

Ø D	H	B
30	33,3	8
40	43,3	12

ELEKTROMATEN	L1	L2	L3	L4
SI 10.15	410	237	341	105
SI 17.15	432	244	348	105
SI63 25.15	436	256	360	130

- Permitted installation: Horizontal (as shown) or vertical (motor at the bottom)
- Customised designs of the SI 25.15 are realised, in part, with the SG85F gearbox series (see 4.2, please contact us, in case of queries)

### 4.2 SI 25.10 – SI 65.15

SG85F

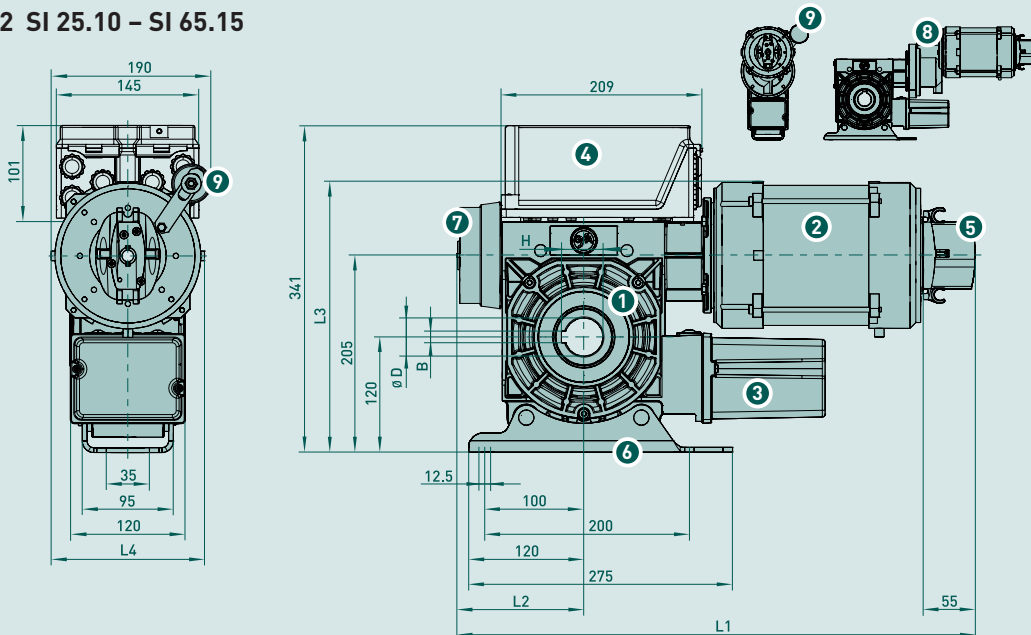

- 1 Worm gear with safety brake
- 2 Motor
- 3 Limit switch
- 4 Optional: WS 900 control panel, removable, with 0,8 m cable
- 5 Hand crank NHK
- 6 Floating foot
- 7 Brake
- 8 Intermediate gear
- 9 Capacitor

ELEKTROMATEN	Ø D	H	B	L1	L2	L3	L4
SI 25.10	30	33,3	8	497	120	271	130
SI 25.15 WS 9	30	33,3	8	523	120	281	152
SI 40.10	40	43,3	12	520	120	271	130
SI 40.15	40	43,3	12	487	120	271	130
SI 45.7 WS 8 9	40	43,3	12	624	120	337	152
SI 55.10 7	40	43,3	12	535	131	281	152
SI 55.15 7	40	43,3	12	535	131	281	152
SI 65.10 7	40	43,3	12	535	131	281	152
SI 65.15 7	40	43,3	12	535	131	281	152

- Permitted installation: Horizontal (as shown) or vertical (motor at the bottom; SI 65.10/65.15 only with torque bracket (page 1.056 Section 6.3))

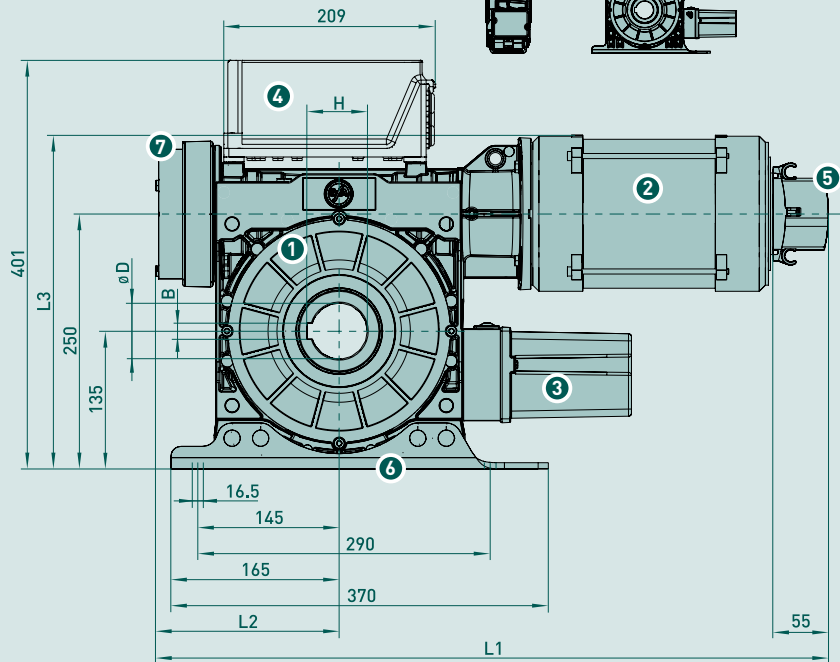
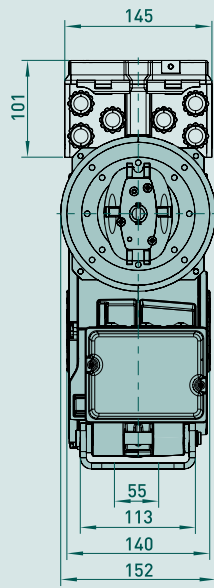

- 1 Worm gear with safety brake
- 2 Motor
- 3 Limit switch
- 4 Optional: WS 900 control panel, removable, with 0,8 m cable
- 5 Hand crank NHK
- 6 Floating foot
- 7 Brake
- 8 Intermediate gear
- 9 2nd brake

ELEKTROMATEN	ØD	H	B	L1	L2	L3
SI 75.10	55	59,3	16	659	179	326
SI 75.15	55	59,3	16	659	179	326
SI 100.10	55	59,3	16	669	179	326
SI 140.7 <sup>8</sup>	55	59,3	16	738	180	382
SI 180.6 <sup>8 9</sup>	60	64,4	18	805	180	382

■ Permitted installation: Horizontal (as shown), vertical (motor at the bottom) only with torque bracket (page 1.056 Section 6.3)

## 5. Emergency manual operation • for horizontal or vertical installation

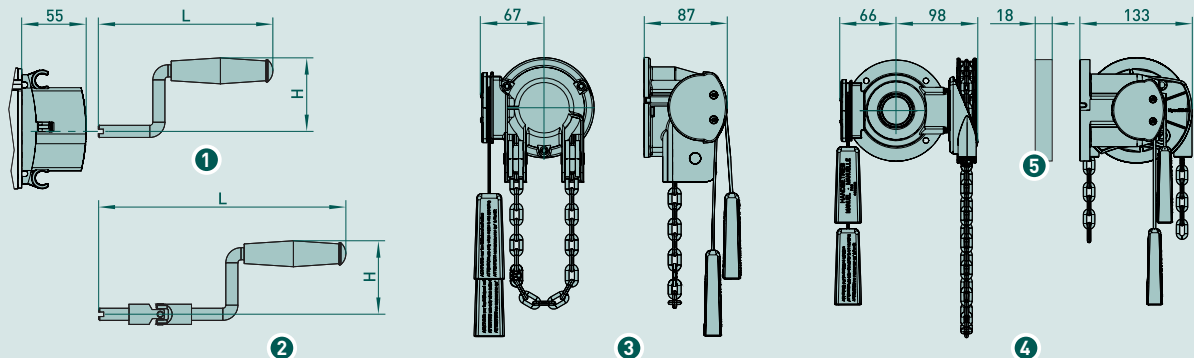

- 1 Manual hand crank operation NHK (Standard)
- 2 Manual hand crank operation with knuckle joint NHKK
- 3 Rapid hand chain operator SK (SI 10.15)
- 4 Hand chain operator KNH (from SI 17.15)
- 5 Flange in-use with: SI 180.6

	For Series	Part.-no.	Ø	L	H
1	SG63F (only for SI 10.15)	30002591	10	255	92
1	SG63F / SG85F	30002749	12	235	122
1	SG115F	30003112	12	265	192
2	SG63F (only for SI 10.15)	30002715	10	415	111
2	SG63F / SG85F	30002750	12	425	152

■ Manual forces, see item 1 of technical data

■ Read note in 3.4

## 6. Attachments / Accessories

### 6.1 Bracket

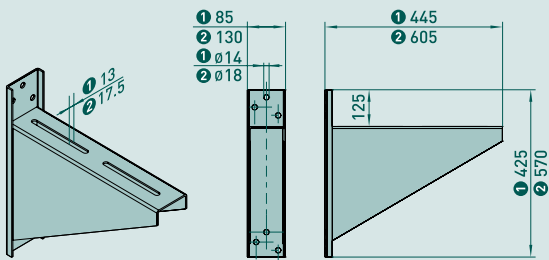

Series	Part no.	Max. load
SG63F / SG85F ①	40006488	5 kN
SG115F (≤ SI 140.7) ②	40012396	12 kN

### 6.2 Bracket (SI 180.6)

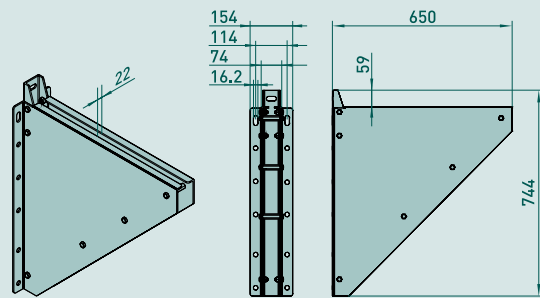

Series	Part no.	Max. load
SG115F (SI 180.6)	40016189	29 kN

### 6.3 Torque bracket

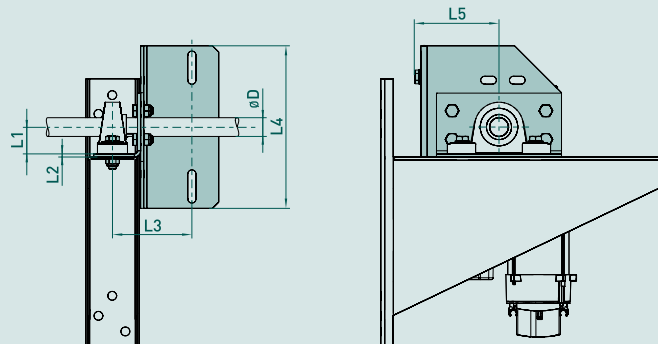
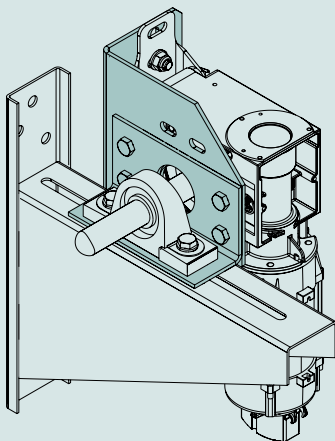

Series	Ø D	Part no.	L1	L2	L3	L4	L5
SG63F / SG85F	30	30002930	42,9	5	127	260	135
SG85F	40	30002930	49,2	5	127	260	135
SG115F	55	30003162	63,5	6	174	350	148
SG115F	60	30003162	69,8	6	174	350	148

- Right- or left-hand use
- ELEKTROMATEN vertical (as shown) or horizontal

- For mounting with floating foot additional requirements: Bracket 6.1 or 6.2 and bearing

### 6.4 Moving-torque bracket

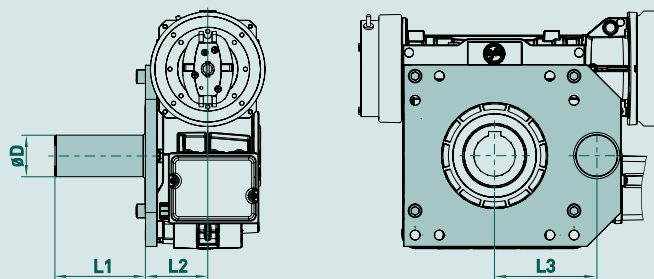
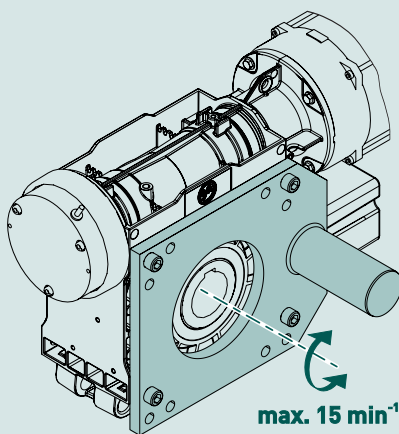

Series	Ø D	Part no.	L1	L2	L3
SG63F <sup>1)</sup>	30	20002641.00004	70	72,5	95
SG85F	30	20002494.00024	80	70	105
SG85F	40	20002494.00025	80	70	105
SG115F <sup>2)</sup>	55	20002495.00004	120	83	135

- Right- or left-hand use
- ELEKTROMATEN horizontal (as shown) or vertikal

- 1) Special version of ELEKTROMATEN with side thread is required
- 2) No use with SI 180.6